

New Generation Machine

Someday all semi strappers will be made in this way



GENESIS TP-502

Main Features:

- ▶ **Compact Mechanical Strapping Head**
With 30% less moving parts than conventional machines substantially reduces maintenance issues. There are no belts, chains or pulleys. Extremely low noise sealing head.
- ▶ **Electronic Tension Control**
Adjustment for wider strap tension (8-45 kg) can be easily done on the front control panel.
- ▶ **Sensor Controlled Heater**
The faster 24V heating mechanism is sensor controlled assuring you of consistent and high efficiency seals.
- ▶ **Large Main Switch**
The lockable CE rated large main power switch increases safe operation of the machine.
- ▶ **Adjustable Table Height**
The table height is adjustable to any height between 780 mm and 950 mm.

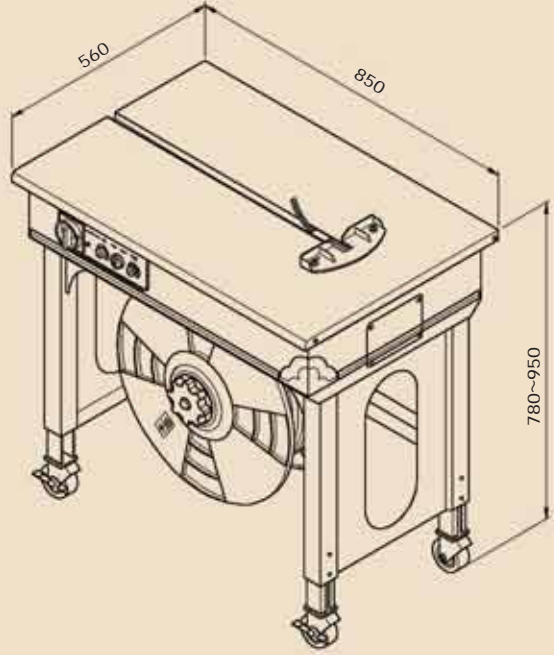

TP-502 TECHNICAL DATA

Strap Width: 5 mm-13 mm
Strap Tension: 8-45 kg
Adjustable Table Height: 780 mm-950 mm
Net Weight: 70 kg
Power: 110V, 220V, 230V 50/60Hz 1PH

Options

- ▶ Conversion kit for small packages
- ▶ Digital readout for tension and feed settings

All specifications are subject to change without notice.



9F-4, NO.112, SEC. 2, CHUNG SHAN N. ROAD, TAIPEI 104, TAIWAN
MAILING ADDRESS : P.O.BOX 68-1951, TAIPEI 104, TAIWAN
TEL : (02) 2581 0126 FAX : 886 2 2562 9849
WEB : www.transpakcorp.com E-mail : transpak@transpak.com.tw

Made in Taiwan

01.2008x2000

SEMI-AUTO STRAPPING MACHINE

These machines are our most economical solution for Semi-Auto application. For low to medium volume strapping, our Semi-Auto machine is your best choice. In this category, we have two product lines:

- Economy machine TP-202, TP-203, TP-202L
- New generation machine Genesis TP-502



TP-202

Economy Machine

The best sales in the world

Mr. Reliable

TP-202

Main Features:

- ▶ High engineering standard and simple design



- ▶ Easy operation, simple maintenance
- ▶ Hinged stainless top plate
- ▶ Mechanical outside tension control
- ▶ Rigid castors with brake
- ▶ Energy efficient, motor only runs as needed
- ▶ Reliable P.C. Board electric control
- ▶ Affordable for every budget, total value more than competing brands
- ▶ Proven quality with over 120,000 sets sold
- ▶ Meet your variable applications, for example:



TP-202 TECHNICAL DATA

Strap Width: 6 mm-15.5 mm
Strap Tension: 15-45 kg
Net Weight: 85 kg
Power: 110V, 220V, 230V 50/60Hz 1PH

Option

- ▶ Adjustable table height from 760 mm to 930 mm

Economy Machine

The best sales in the world

Mr. Reliable

TP-203

Main Features:

- ▶ Mid-sized model
- ▶ Smoke-exhaustion system
- ▶ Designed specially for office, bank, post office, book and department store...etc.
- ▶ Other main features please refer to TP-202

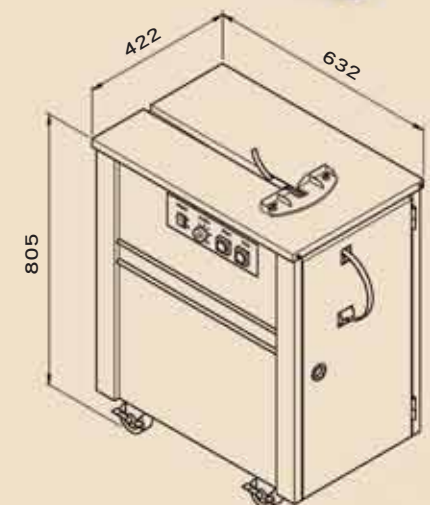

TP-203 / TP-202L TECHNICAL DATA

Strap Width: 6 mm-15.5 mm
Strap Tension: TP-203: 9-30 kg
TP-202L: 15-45 kg
Net Weight: 80 kg
Power: 110V, 220V, 230V 50/60Hz 1PH



Mr. Reliable

TP-202L

Main Features:

- ▶ Low-table model
- ▶ Designed to accommodate tall or heavy packages
- ▶ Other main features please refer to TP-202

